

P E R M I T

CITY OF NAPOLEON  
255 W. RIVERVIEW AVE  
NAPOLEON, OHIO 43545

DIVISION OF BUILDING & ZONING  
PH (419) 592-4010  
FAX (419) 599-8393

PERMIT NO: 820      DATE ISSUED: 10-08-01      ISSUED BY: SKE

JOB LOCATION: 1815 SCOTT ST      EST. COST:

LOT #:      SUBDIVISION NAME:

OWNER: WALMART STORES, INC.  
ADDRESS: 1815 SCOTT ST  
CSZ: NAPOLEON, OH 43545  
PHONE:

AGENT: SIGN CRAFTERS, INC.  
ADDRESS: 1508 STRINGTOWN ROAD  
CSZ: EVANSVILLE, IN 47711  
PHONE: 800-742-3655

USE TYPE - RESIDENTIAL:

OTHER:

ZONING INFORMATION

DIST:      LOT DIM:      AREA:      FYRD:      SYRD:      RYRD:  
MAX HT:      # PKG SPACES:      # LOADING SP:      MAX LOT COV:

BOARD OF ZONING APPEALS:

WORK TYPE - NEW: X      REPLMNT:      ADD'N:      ALTER:      REMODEL:

WORK INFORMATION

SIZE - LGTH:      WIDTH:      STORIES:      LIVING AREA SF:  
GARAGE AREA SF:      HEIGHT:      BLDG VOL DEMO PERMIT:

WORK DESCRIPTION  
POLE & WALL SIGN

FEE DESCRIPTION

PAID DATE      FEE AMOUNT DUE

SIGN PERMIT

100.00

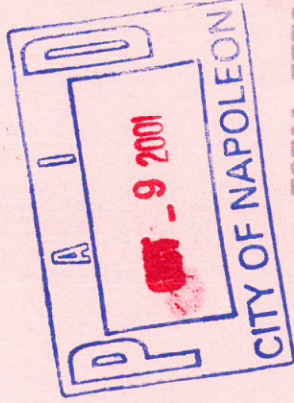

TOTAL FEES DUE

100.00

-----  
DATE

-----  
APPLICANT SIGNATURE

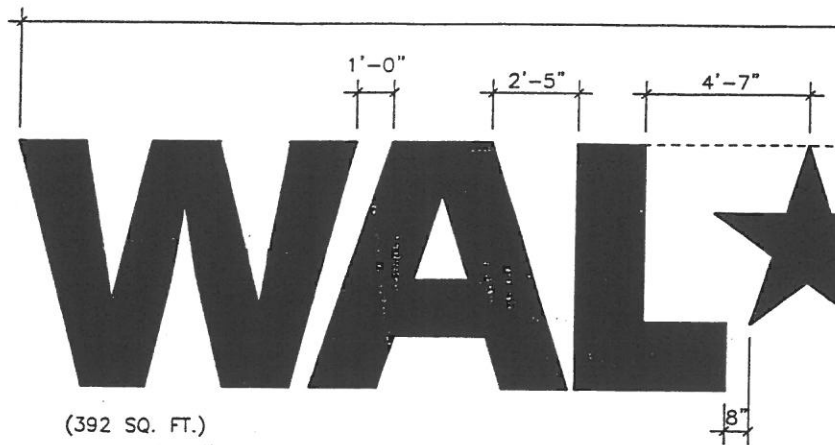

① SPACING DIMENSIONS

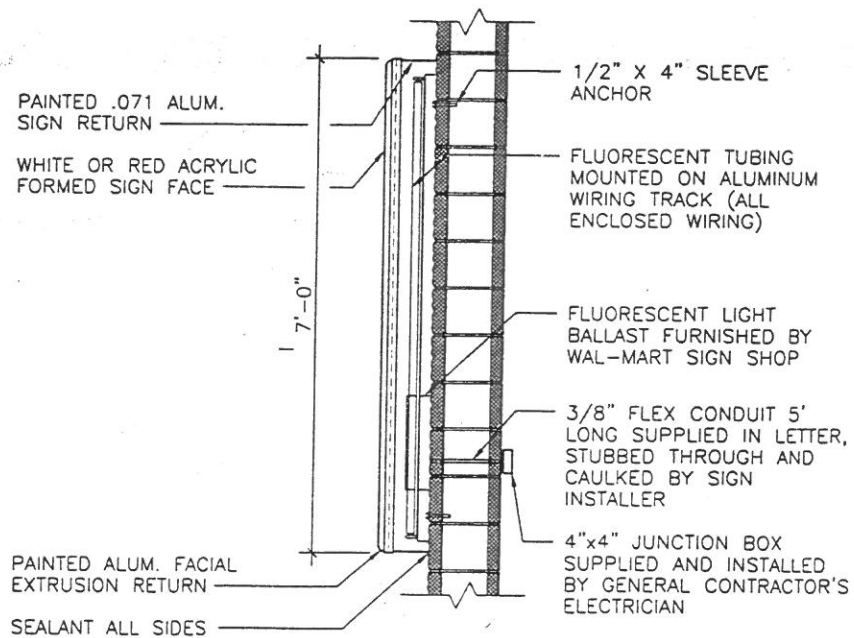

② 7'-0" SIGNAGE SECTION

N.T.S.

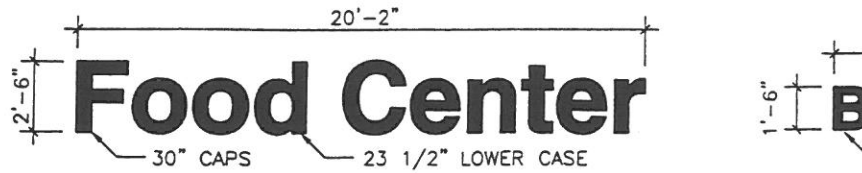

HELVETICA MEDIUM STUD MOUNT PLASTIC LETTERS

(1)

① SPACING DIMENSIONS N.T.S.  
(50.47 SQ. FT.)

② SPAC

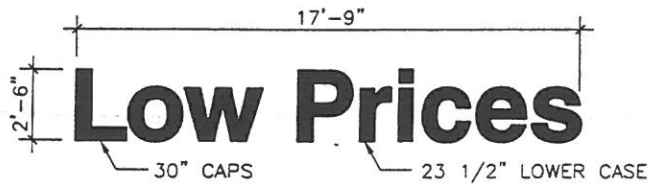

③ SPACING DIMENSIONS N.T.S.  
(44.38 SQ. FT.)



HELVETICA MEDIUM STUD  
MOUNT PLASTIC LETTERS

④ SPACING DIMENSIONS N.T.S.  
(68.20 SQ. FT.)



⑥ SPACING DIMENSIONS N.T.S.  
HELVETICA MEDIUM WITH 15° SLANT  
STUD MOUNT PLASTIC LETTERS

NOTE: DRAWINGS ON

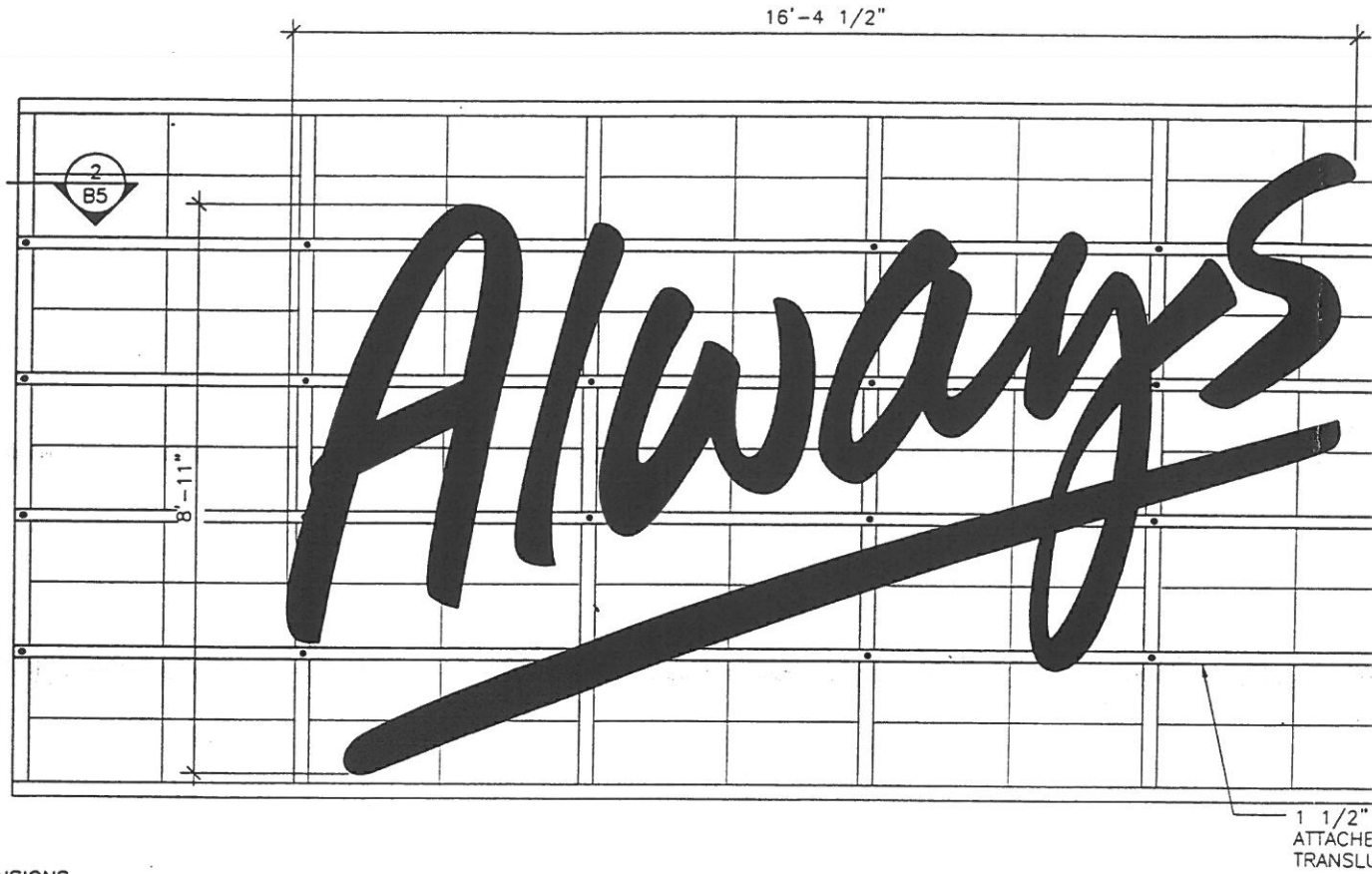

① SPACING DIMENSIONS

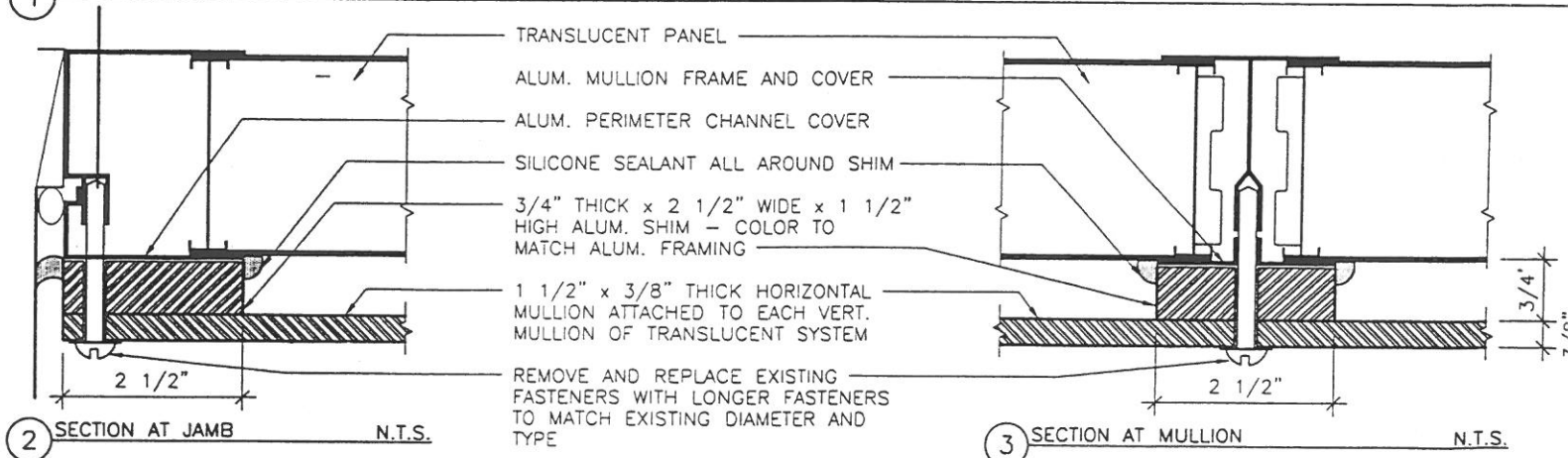

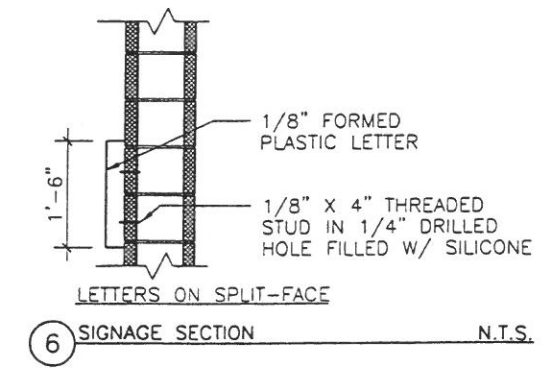
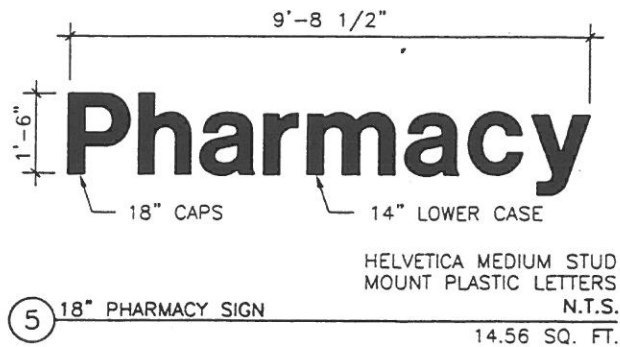
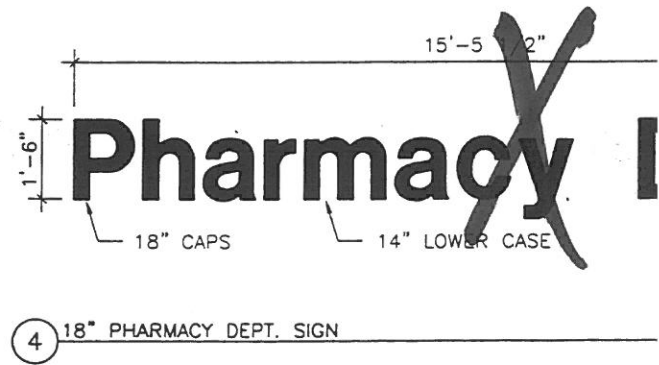
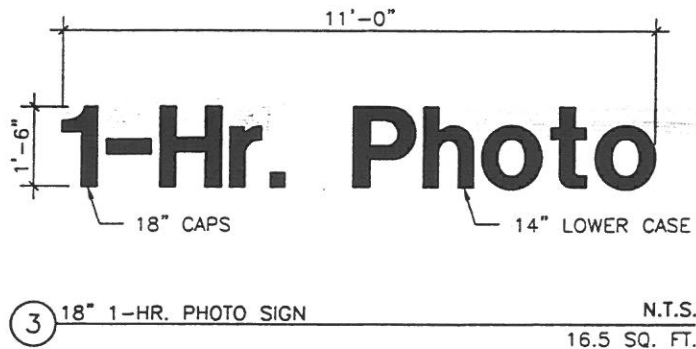
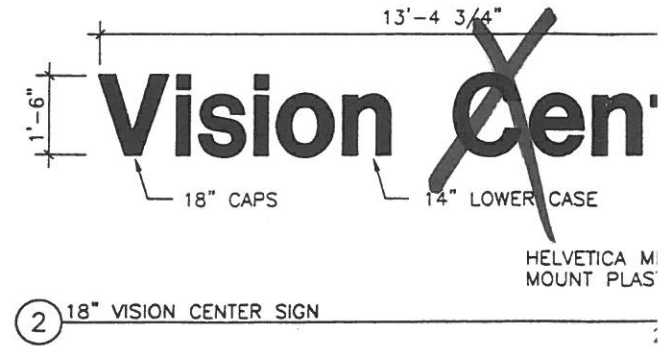
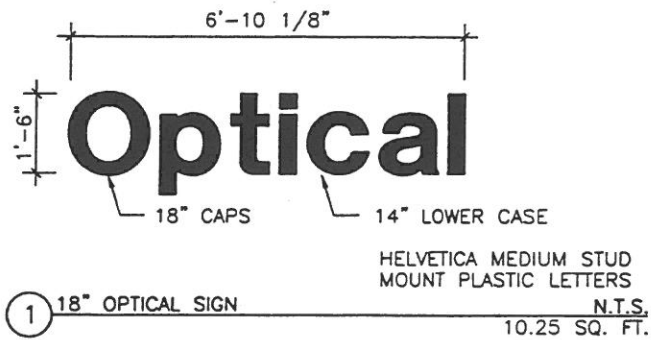



LEFT SIDE  
TLE STOREFRONT

THE ARROW LINES UP WITH  
THE END OF THE LETTER  
"e"

THE ARROW LINES UP WITH  
THE TOP AND BOTTOM OF  
OF LETTER "E"

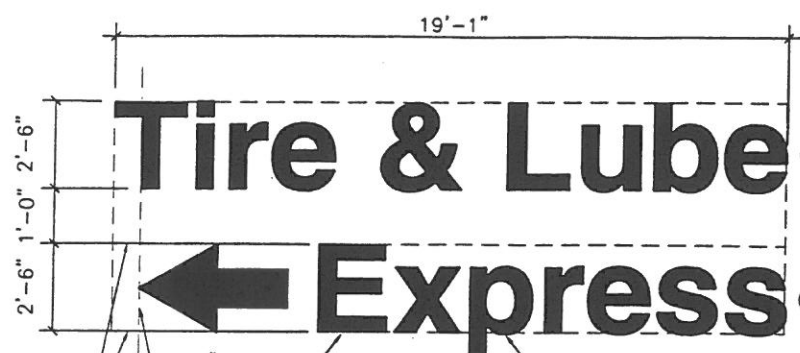

(47.7 SQ. F

(32.88 SQ.

30" CAPS

THE ARROW LINES UP  
WITH THE STEM OF THE  
LETTER "T"

22 1/2" LOWER CASE

RIGHT SIDE  
TLE STOREFRONT

1 FRONT ELEVATION

N.T.S.



24" CAPS

LEFT SIDE  
TLE STOREFRONT

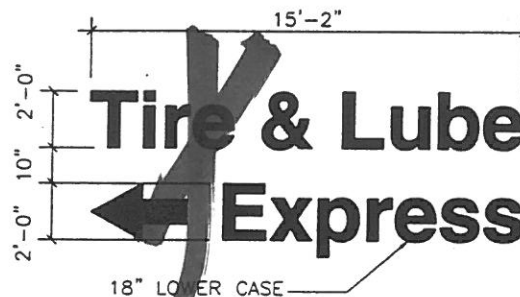

(30.3 SQ. FT.)

(21.0 SQ. FT.)

18" LOWER CASE

RIGHT SIDE  
TLE STOREFRONT

2 FRONT ELEVATION

N.T.S.

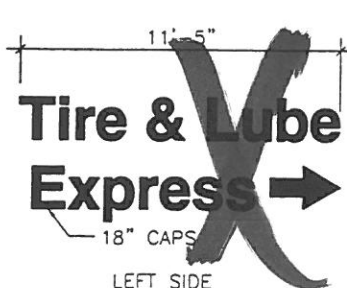

18" CAPS

LEFT SIDE  
TLE STOREFRONT



LOWER CASE

RIGHT SIDE  
TLE STOREFRONT

N.T.S.

3 FRONT ELEVATION

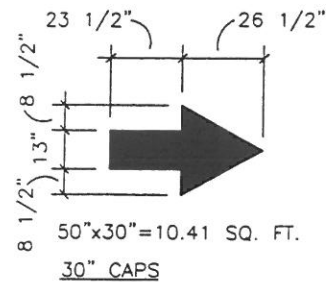

50"x30"=10.41 SQ. FT.

30" CAPS

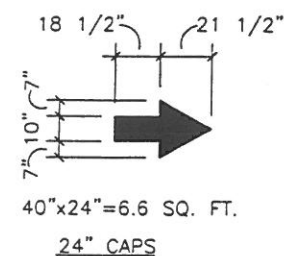

40"x24"=6.6 SQ. FT.

24" CAPS

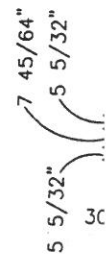

4 ARROW DIMENSIONS

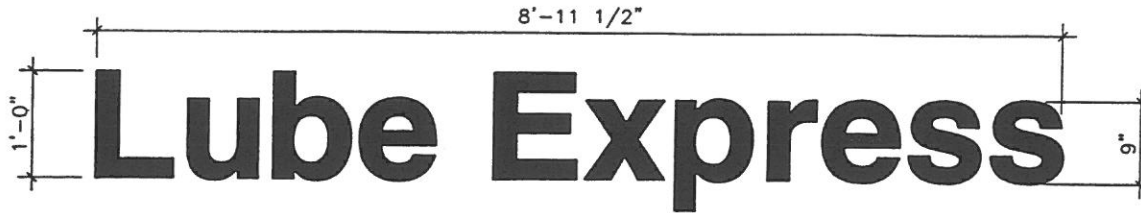

(8.96 SQ. FT.)  $\times 2 = 17.92 \text{ sq. ft.}$



(2.75 SQ. FT.)

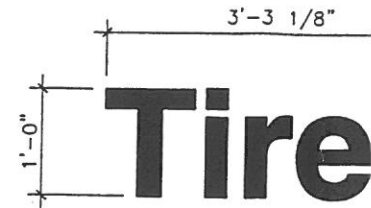

(3.26 SQ. FT.)  $\times 9$



(11.01 SQ. FT.)

1 SERVICE BAY SIGNAGE - A

N.T.S.

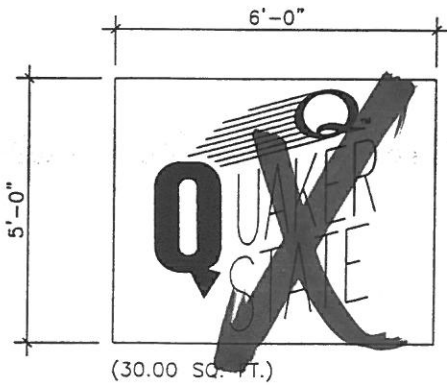

(30.00 SQ. FT.)

OR

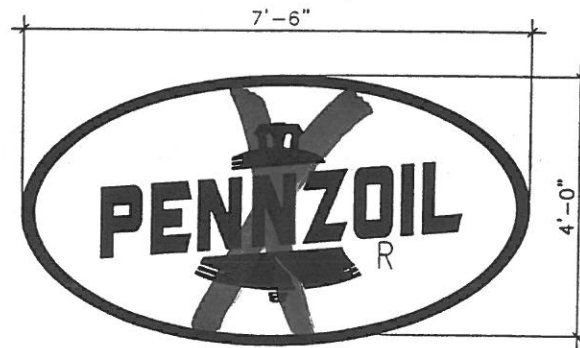

(30.00 SQ. FT.)

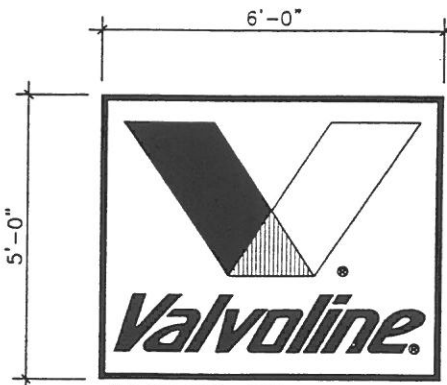

(30.00 OSQ. FT.)

OR

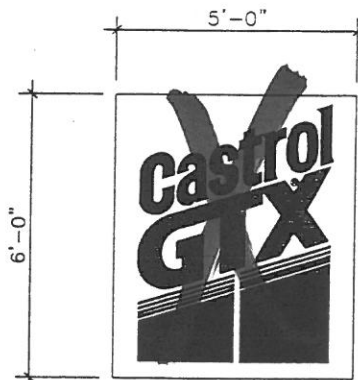

(30.00 OSQ. FT.)

2 SERVICE BAY SIGNAGE - B



(108.51)

3 TLE FRONT ELEVATION SPACING

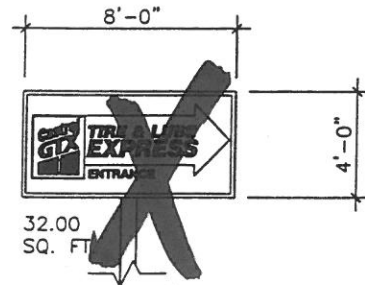
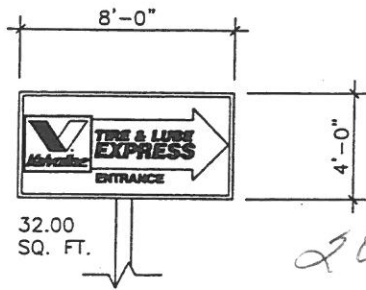

*20' high*

1 FRONT VIEW N.T.S.

2 FRONT VIEW N.T.S.

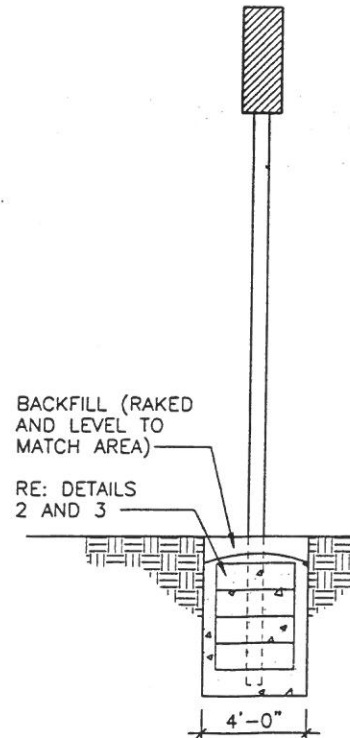
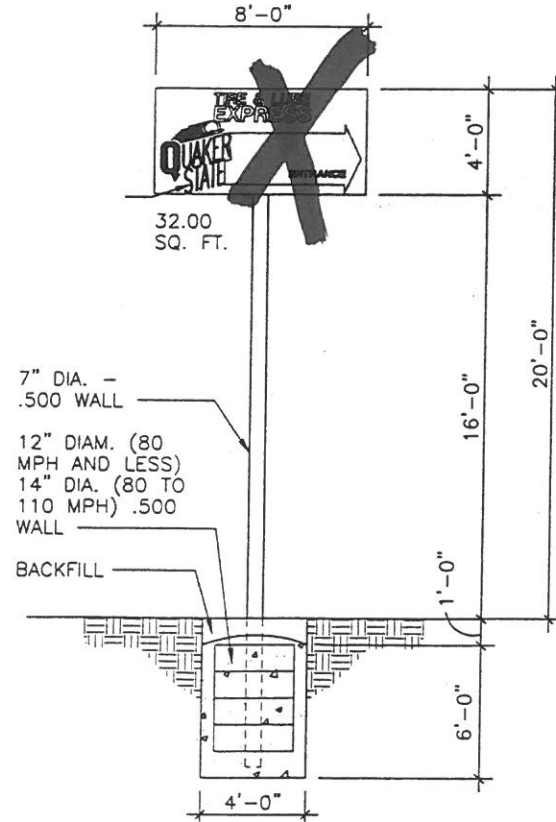
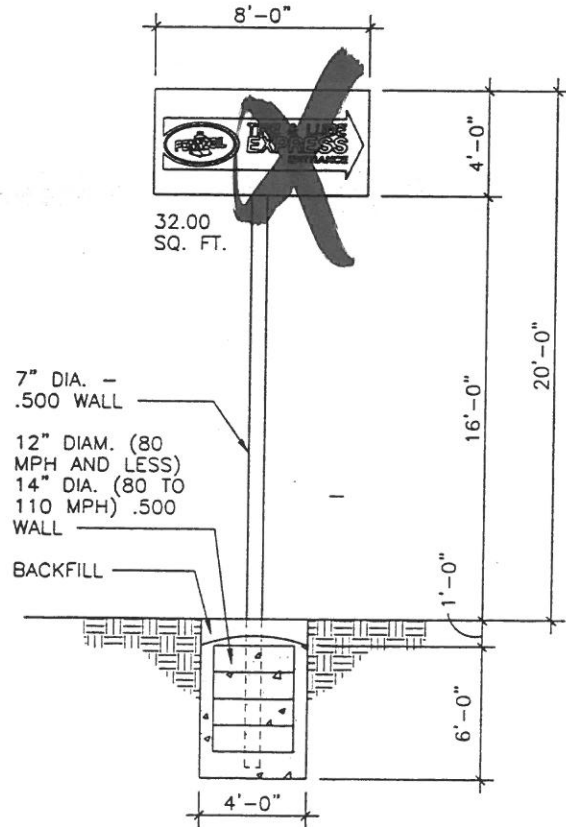

3 FRONT VIEW N.T.S.

4 FRONT VIEW N.T.S.

5 SIDE VIEW





1508 Stringtown Road · P.O. Box 4266 · Evansville, IN 47711 · Phone (812) 424-9011

October 05, 2001

Brent Damman  
Building Commissioner  
City of Napoleon, Ohio  
255 West Riverview Avenue  
Napoleon, OH 43545

Re: Wal\*Mart #1416, 1815 Scott Street, Napoleon, OH

Dear Brent:

As per our phone conversation 10/4/01, I understand that the signs for this location has been previously approved. I have enclosed drawings of the signs and would like for you to make sure that they are what was approved. I have also enclosed a storefront elevation, site plan, permit application, and contractor's registration form with a check in the amount of \$25.00 to cover the fee.

After your review please contact me at 1-800-742-3655 and let me know how to proceed.

A handwritten signature in cursive script that reads "Judy Harmon".

Judy Harmon  
Sign Crafters, Inc.

# City of Napoleon Engineering Department

## Application for Sign Permit

Office Use Only	_____
Permit No:	_____
App. Date:	_____
Est. Cost:	_____
Base Fee:	<u>25.00</u>
Plus Fee:	<u>75.00</u>
Total Fee:	<u>100.00</u>

Owner Name: Wal\*Mart Stores, Inc.

Owner Address: 2001 Southeast 10th Street, Bentonville, AR 72716-0550

Contractor Name: Sign Crafters, Inc.

Contractor Address: 1508 Stringtown Road  
Evansville, IN 47711      PH: 812-424-9011

Location of Project: 1815 Scott Street

Additional Information: Sign Type - Pole  Post  Wall  Ground  Awning

Dimensions: see attached      Total S.F. 1292.58

Date: 10/5/01      Applicant Signature: Judy Hamer

Application must include a site drawing or a description of the location of the sign (where applicable) and a sketch of the proposed sign(s).

The permit fee is as follows: \$25.00 base which includes up to 50 square feet of sign area, plus .10 per square foot after 50 square feet, not to exceed \$100.00 in any case.